





GLOBAL SOLUTIONS
SOLUTIONS GLOBALES
SOLUCIONES GLOBALES
SOLUZIONI GLOBALI





 According with fire doors certificates, our fire doors represent the widest range of finishings and qualities certificates according with norms UNE, UNI, ARRETE, BRITISH, DIN, PN-B

 Conformes aux exigences des normes de résistance au feu, nos portes battantes coupe-feu possèdent une large gamme de finitions de qualité certifiée par les normes UNE, UNI, ARRETE, BRITISH, DIN, PN-B.

 Conforme all'esigenze di resistenza al fuoco, le nostre porte tagliafuoco battenti rappresentano la più ampia gamma di finiture e qualità certificate con le norme UNE, UNI, ARRETE, BRITISH, DIN, PN-B.

 En conformidad a las exigencias de resistencia al fuego, nuestras puertas cortafuegos batientes representan la más amplia gama de acabados y calidades certificadas con las normas UNE, UNI, ARRETE, BRITISH, DIN, PN-B.

Fire doors Coupe-feu
Tagliafuoco Cortafuegos

NOVA CLASSIC EXECUTIVE GAMACOLOR

series Equipment
accessoires de série
accesorios de serie
accessori di serie



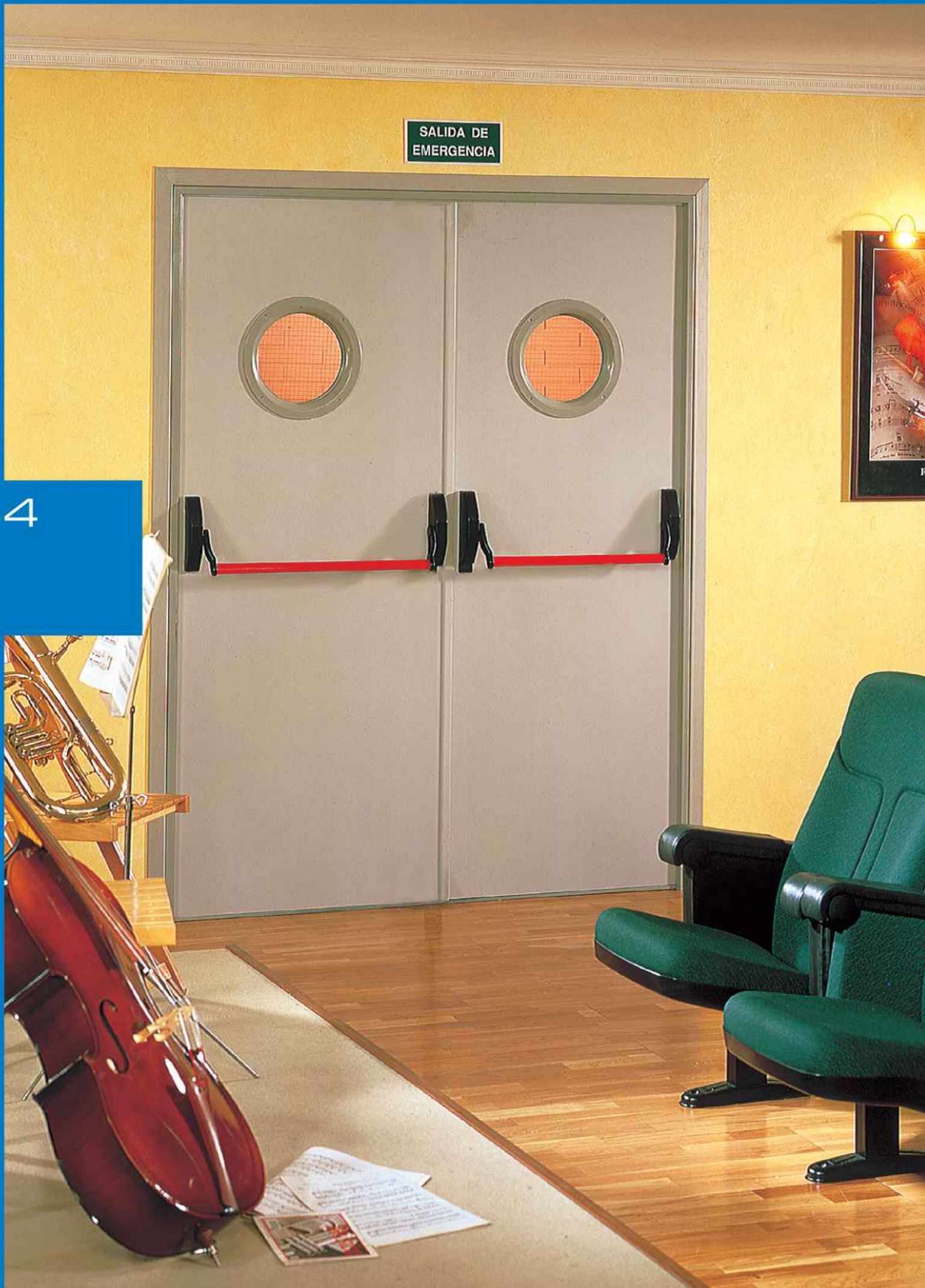



4



 Our acoustic fire resistant doorsets are made according with ISO 140/3, ISO 717/1 and ISO 717/2. These range of doors represent the ideal solution for acoustic, thermal isolation and fire resistance in cinemas, auditoriums, and discotheques...

 Nos portes acoustiques RF, conformes aux normes ISO 140/3, ISO 717/1 et ISO 717/2, sont une solution permettant l'isolement acoustique, thermique et une haute résistance au feu idéale pour les cinémas, les auditorios, les discothèques...

 Le nostre porte acustiche REI conforme alla normativa ISO 140/3, ISO 717/1 e ISO 717/2 sono la soluzione ideale per l'isolamento acustico, termico e resistente al fuoco in sale di cinema, uditori, discoteche...

 Nuestras puertas acústicas RF conforme a normativa ISO 140/3, ISO 717/1 y ISO 717/2 son la solución ideal para el aislamiento acústico, térmico y resistente al fuego en cines, auditorios, discotecas...

Acoustic line RF Acoustiques CF
Acustiche REI Acústicas RF

acoustics seal
joints acoustiques
juntas acusticas
guarnizion acustiche

-  **1 JF3**
Frame seal.
Joint de cadre.
Junta de marco
Guarnizione di telaio
-  **2 JF1**
Leaf seal
Joint de vantail.
Junta de hoja
Guarnizione di anta
-  **3 JAI1**
Intumescent acoustic frame seal
Joints intumescents acoustiques.
Junta intumescente acústica marco
Guarnizione intumescente acustica telaio
-  **4 GS1**
Acoustic seals
Juntas Acústicas
Juntas acústicas
Guarnizioni acustiche
-  **5 PP2**





 The new regulation for fire doors in hotels made us develop the highest performance range in finishings, with a perfect combination between our robust manufacture and fine natural wood.

 Les normes de plus en plus exigeantes en terme de portes coupe-feu pour hotels nous ont poussées à développer une ligne très sophistiquée en finitions, combinant la robustesse de nos portes avec la noblesse du bois naturel.

 La nuova ed esigente normativa in porte resistenti al fuoco per alberghi ci ha fatto sviluppare la gamma più alta in finiture, combinando la robustezza delle nostre porte con la nobiltà del legno naturale.

 La nueva y exigente normativa en puertas resistentes al fuego para hoteles nos hizo desarrollar la gama más alta en acabados, combinando la robustez de nuestra puertas con la nobleza de la madera natural.



Hotel Fire Doors

SUITE / PALACE / ROYAL



HOPPE



SENA



MH3CISA



CISA ELECTRONIC LOCK
CISA ELECTRONIQUE
CISA ELECTRONICA
CISA ELETTRONICA



BAHTROOM ECO LOCK
ECO TOILETTES
ECO BANO
ECO BAGNO



TESA ELECTRONIQUE
TESA ELECTRONIC LOCK
TESA ELECTRONICA
TESA ELETTRONICA







102



 Hospital range has been specifically developed for projects that need our high performance steel plate certified against bacteria adhesion and facilitates its cleaning with the maximum hygiene.

 La gamma sanitaria è specialmente sviluppata per installazioni che hanno bisogno delle nostre finiture più esigenti che sono certificate contro l'aderenza di batteri e facilitano la loro pulizia con le massime garanzie d'igiene.

 La ligne sanitaire est spécialement conçue pour les installations qui requièrent des certificats spécifiques contre l'adhérence des bactéries et qui facilitent le nettoyage, assurant ainsi une hygiène maximum.

 La gama sanitaria está especialmente desarrollada para instalaciones que necesitan de nuestros acabados más exigentes certificados contra la adherencia de bacterias y facilitan su limpieza con las máximas garantías de higiene.



Hospital Hôpital
Ospedale Hospital

optional/optionnel/opcional/opzionale



 Sanitary / Sanitaire
Sanitario / Sanitario

  Fireproof / Coupe-feu
Cortafuegos / Tagliafuoco

  Smokeproof / Anti-fumée
Cortahumos / Taglia Fummi

  Acoustic / Acoustique
Acústica / Acustica

 Sanitary color range
Gamme de couleur sanitaire
Gama de color sanitario
Gamma di colore sanitario

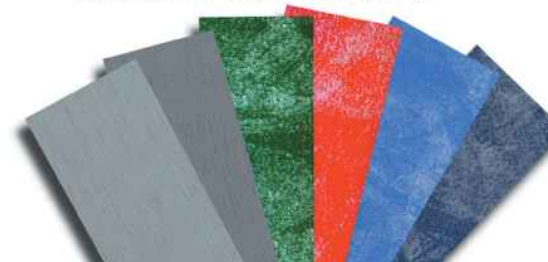



 Our security doors have been certified in class II, III and IV according to the new norm EN-1627/1630 which regulates high security performance products.

 Nos portes de sécurité ont été certifiées en classe II, III et IV conformes aux exigences de la norme EN-1627/1630 qui régle tous les produits de haute gamme en terme de sécurité.

 Le nostre porte di sicurezza sono state certificate in classe II, III e IV conforme alla esigente normativa EN-1627/1630 che regola i prodotti di alta gamma di sicurezza.

 Nuestras puertas de seguridad han sido certificadas en clase II, III y IV conforme a la exigente normativa EN-1627/1630 que regula los productos de alta gama en seguridad.



Security Sécurité
Sicurezza Seguridad

series Equipment
accessoires de série
accesorios de serie
accessori di serie



Draught excluder
Bourrelet
Burliete
Paraspifferi



Hinge
Charnière
Bisagra
Cerniera



Anti-crowbar Device
Rostre Anti-effraction
Punto Antipalanca
Punto Antileva



Security latch (optional)
Sélecteur d'ouverture
Limitador apertura (opcional)
Limitatore apertura



1 Point security Lock
1/2 Point
1/2 Puntos
1/2 Punti



3 Points security lock
3 Points
3 Puntos
3 Punti

optional
optionnel
opcional
opzionale

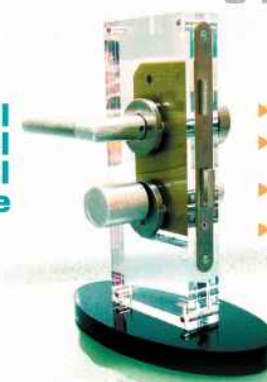

- ▶ Personalice electromagnet lock
- ▶ Serrures électro-magnétiques personnalisées (optionnel)
- ▶ Cerraduras electromagnéticas personalizadas
- ▶ Serrature elettromagnetiche personalizzate (opzionale)







12



 The "Fireglass 50" system allows RF Glass barrier constructions using isolated profiles and RF Pyrostop glasses of 21 mm.

 Le système "Fireglass 50" consiste en la construction de fermetures vitrées coupe-feu RF utilisant diverses types de profils avec isolement et des vitres RF Pyrostop de 21mm.

 Il sistema "FIREGLASS 50" sopporta la costruzione di chiusure vetrate tagliafuoco REI utilizzando diversi tipi di profili con isolamento e vetri REI Pyrostop di 21mm.

 El sistema "FIREGLASS 50" consiente la construcción de cierres vidriados cortafuegos RF utilizando varios tipos de perfiles con aislamiento y vidrios RF Pyrostop de 21mm.

Glasses door RF Vitres CF
Vetro REI Vidrio RF

Double leaf glass section
Section vitrée de deux vantaux.
Sección vidriada doble hoja
Sezione vetrata a doppia

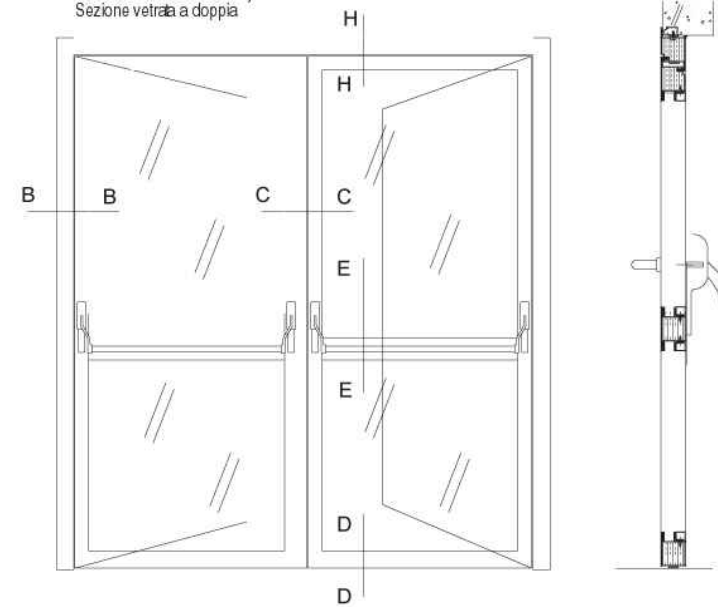

Fitting on wall center
Montage au centre du mur
Montaje centro muro
Montaggio centro muro

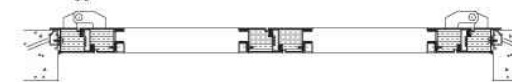

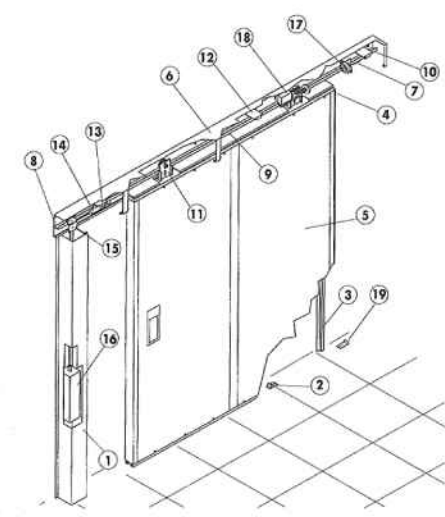

The normative for fire protection in industry has encouraged us to develop a big dimension project, as big as the market requires to create secure isolating compartments up to two hours in commercial centers, theaters or heavy duty industry.

Les exigences en protection contre-incendie pour les installations industrielles nous ont poussées à créer un projet de portes grandes dimensions répondant aux besoins du marché permettant de protéger du feu jusqu'à deux heures les zones sensibles aux incendies, les centres commerciaux, les théâtres où les industries.

L'esigenza in protezione contro incendio in installazioni industriali ci ha fatto realizzare un progetto di grandi dimensioni conforme alle necessità del mercato per fare compartimenti fino a due ore nei settori di incendi, centri commerciali, teatri e industrie.

La exigencia en protección contra incendios en instalaciones industriales nos ha llevado a realizar un proyecto de grandes dimensiones, tanto como necesita el mercado para compartimentar hasta dos horas los sectores de incendios en centros comerciales, teatros o industrias.

Sliding doors RF Portes coulissantes CF
 Scorrevoli REI Correderas RF

Speed control reducer detail
 Reducteur de vitesse contrôlée (VC)
 Detalle reductor de velocidad controlada (VC)
 Dettaglio riduttore di velocità controllata (VC)



Electromagnet detail
 Electro-aimant
 Detalle electroimán
 Dettaglio elettromagneto



Final shock absorbing buffer
 Amortisseur SAM
 Detalle amortiguador final de recorrido SAM
 Dettaglio ammortizzatore finale di percorso SAM



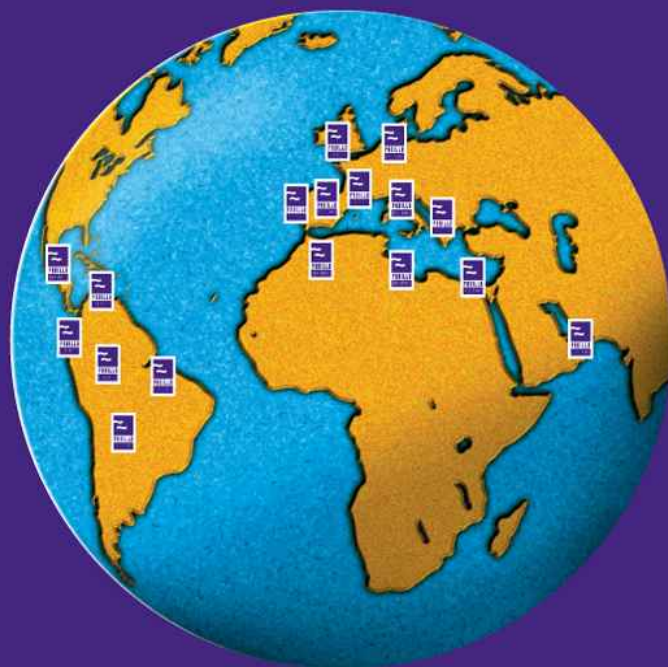

PADILLA

fire doors

CUSTOMER SERVICE

00 34 902 113 687

e-mail: padillafd@padilla-fire-doors.com

[www. padilla-fire-doors.com](http://www.padilla-fire-doors.com)